

SKLADOVA TECHNICA AD



CE[®]

CHAIN ELECTRIC HOIST



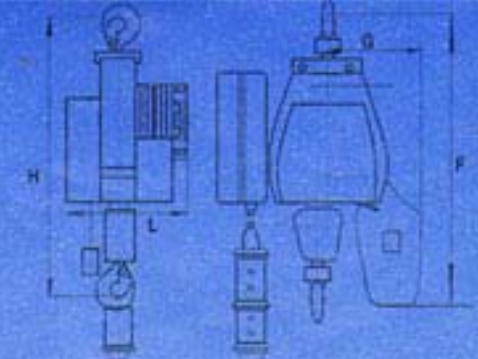
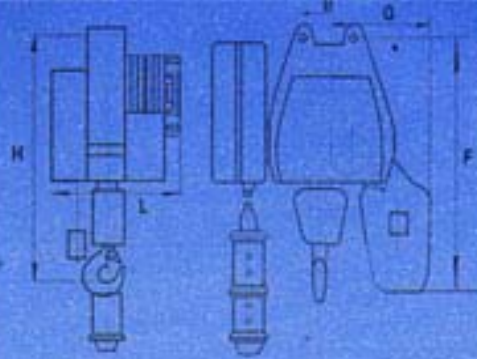

CHAIN ELECTRIC HOIST VERSION		ON LUGS						ON HOOK					
TYPE		B011M	B012M	B013M	B021M	B022M	B023M	B031M	B032M	B033M	B041M	B042M	
LOAD-HOISTING CAPACITY (kg)		125	250	500	250	500	1000	125	250	500	250	500	1000
HOISTING RATE-FREQUENCY		1			2			1			2		
HEIGHT OF HOISTING (m)		6,4			3,2			6,4			3,2		
SPEED OF HOISTING (m/min)	BASIC	8			4			8			4		
	MICRO	2,4			1,2			2,4			1,2		
ELECTRIC MOTOR POWER (kw)	BASIC	0,18	0,36	0,76	0,18	0,36	0,76	0,18	0,36	0,76	0,18	0,36	0,76
	MICRO	0,06	0,10	0,24	0,06	0,10	0,24	0,06	0,10	0,24	0,06	0,10	0,24
VOLTAGE (V)													
EFFICIENCY (%)	BASIC												
	MICRO												
FAILURE STRESS (kg)		2500	5000	2500	5000	2500	5000	2500	5000	2500	5000	5000	
WEIGHT (kg)		23	25	52	23	25	54	24	26	57	25	27	59
SPEED OF MOVEMENT (m/min)													
POWER OF THE ELECTRIC MOTOR FOR MOVEMENT (m/min)													
EFFICIENCY (%)													
WIDTH OF PROFILE (mm)													
MINIMUM RADIUS (m)													
H		404	422	497	465	465	588	498	534	647	577	577	738
P		518	518	598	518	518	598	630	630	748	630	630	748
L		225	242	402	225	242	402	225	242	402	225	242	402
G		200	200	236	200	200	236	200	200	236	200	200	236
B		55	55	100	55	55	100						

PRODUCTOS INNOVADORES Y UNA FIRMA DEDICADA A LA INDUSTRIA MUNDIAL
HAN HECHO DE ESTA EMPRESA INTERNACIONAL LIDER EN POLIPASTOS DE CADENA Y
CABLE DE ACERO.

SEA CUAL SEA SUS REQUERIMIENTOS DE LEVANTAR CARGAS, SEA DONDE SEA QUE
ESTE UD. UBICADO NOSOTROS TENEMOS PARA OFRECERLE:

- POLIPASTO A CADENA
- POLIPASTO A CABLE DE ACERO
- PUENTES GRUA
- INSTALACIONES COMPLETAS DE CARGA Y TRASLADOS
- SISTEMA PLANETARIO DE CAJA DE ENGRANAJE
- CAPACIDADES DE CARGA SEGUN NECESIDADES
- ASISTENCIA TECNICA Y REPUESTOS
- REPRESENTANTES, ASISTENCIA TECNICA

STOIAN CRISTOFF S.A.

MAIPU 1829

TEL.: 481 28 60

FAX.: 487 22 08

DISTRIBUIDOR :